

# MaxxECU

## Notes:

Cable shields should only be grounded through the ECU.  
Text in blue is the cable markings.

### Digital input wiring

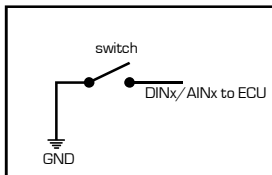

Sensor GND must **NEVER** be connected to chassis ground!

### Wiring alternative for crank / home signal

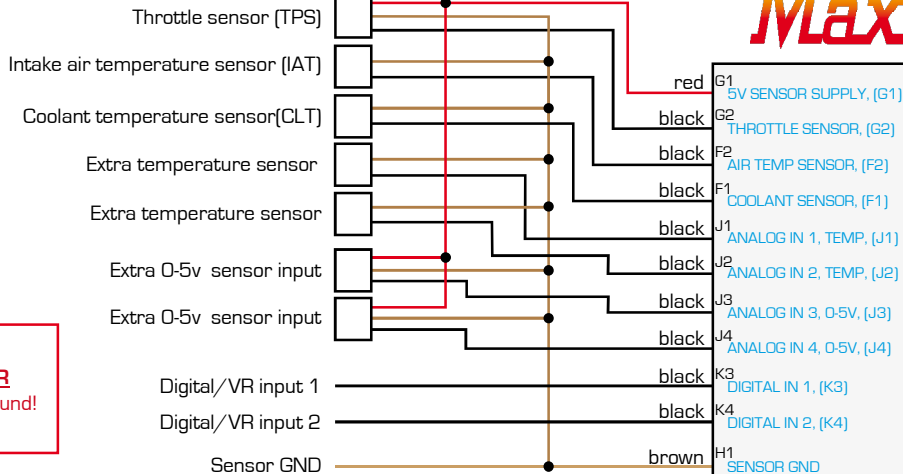
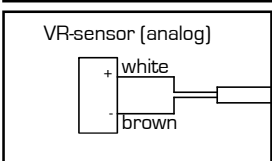
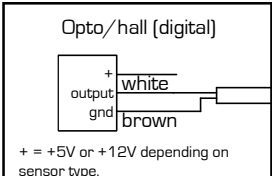

### Wideband lambda sensor 1

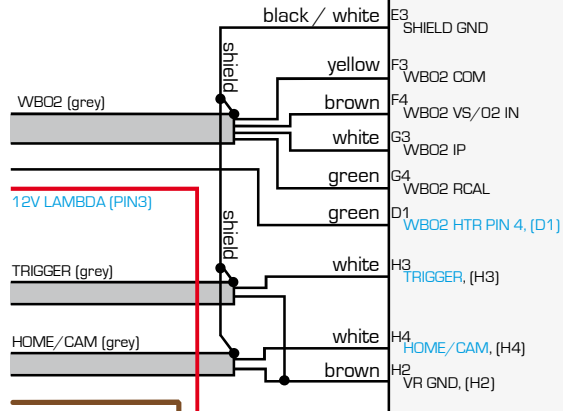

### Crank sensor

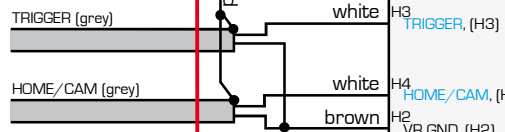

### Home sensor

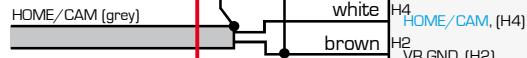

### GND (engine cylinder)



### WBO2 1

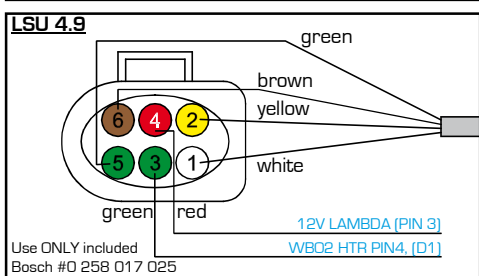
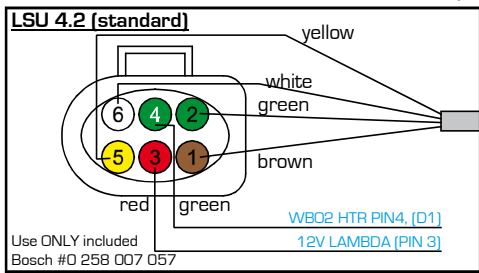

Available pins in connector, use as needed.  
Small pin = max 15A  
Big pin = max 25A

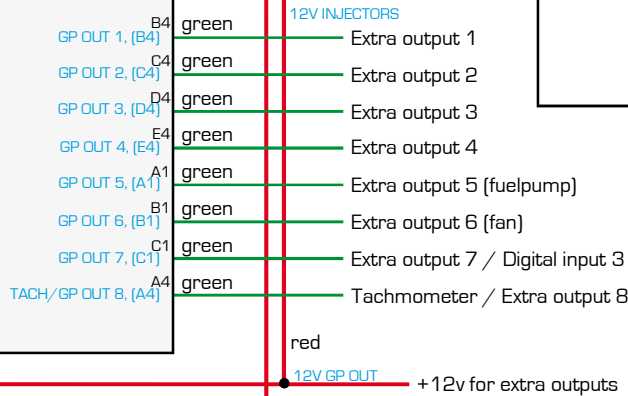
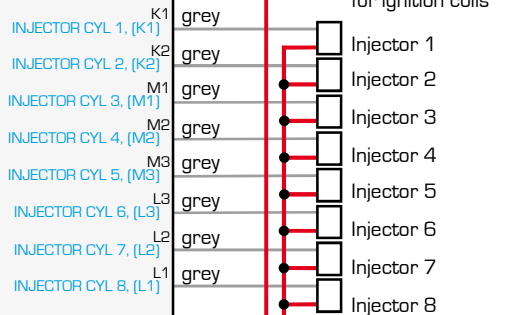
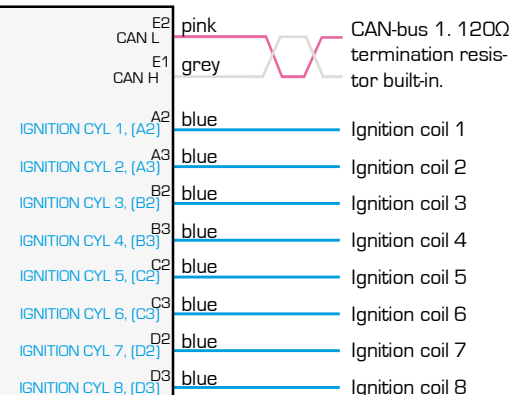

All GPO/INJ has 30V flyback as standard built-in

## Options for connecting ignition coils

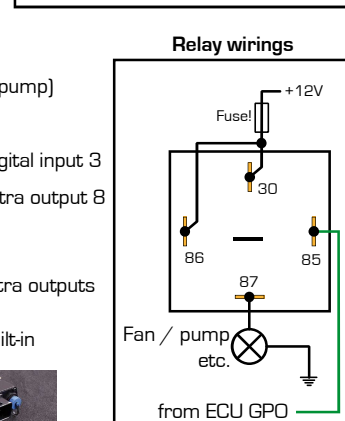
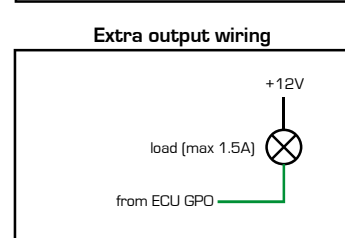
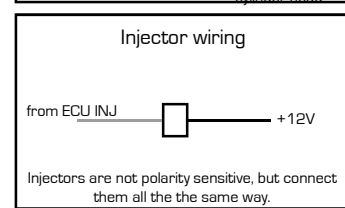
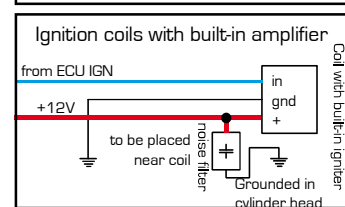
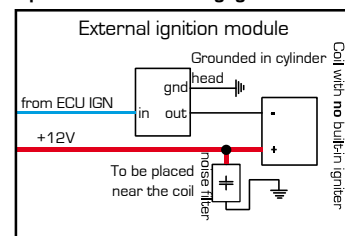

# MaxxECU

CMC	Label	Color
A1	EGT1+	Yellow
A2	EGT2+	Yellow
A3	EGT3+	Yellow
A4	EGT4+	Yellow
B1	EGT1-	Red
B2	EGT2-	Red
B3	EGT3-	Red
B4	EGT4-	Red
C1	EGT5+	Yellow
C2	EGT6+	Yellow
C3	EGT7+	Yellow
C4	EGT8+	Yellow
D1	EGT5-	Red
D2	EGT6-	Red
D3	EGT7-	Red
D4	EGT8-	Red
E1	EGT9+	Yellow
E2	EGT10+	Yellow
E3	EGT11+	Yellow
E4	EGT12+	Yellow
F1	EGT9-	Red
F2	EGT10-	Red
F3	EGT11-	Red
F4	EGT12-	Red
G1	-	-
G2	-	-
G3	-	-
G4	-	-
H1	ENGINE GROUND 2	Brown
H2	ENGINE GROUND 2	Brown
H3	ENGINE GROUND 2	Brown
H4	-	-

Connectors			Connectors		
ANSI Code	ANSI/ASTM E-230 Color Coding		IEC 584-3 Color Coding		IEC Code
	Thermocouple Grade	Extension Grade	Thermocouple Grade	Intrinsically Safe	
J					J
<b>K</b>					<b>K</b>
T					T
E					E
<b>N</b>					<b>N</b>

MaxxECU supported type

MaxxECU supported type

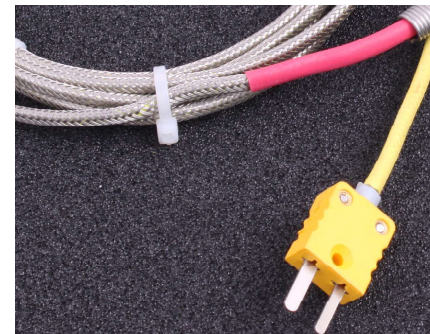

Use only Type K cables and connectors.

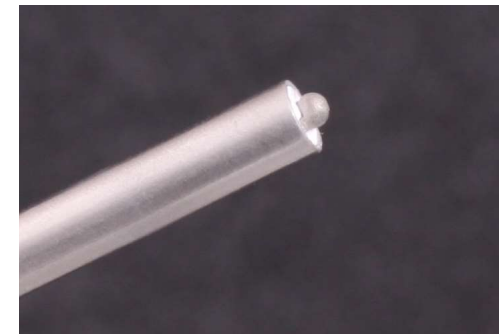

The tip of the sensor must be isolated from ground.



MaxxECU PRO  
Connector 2

# MaxxECU

## Notes:

Cable shields should only be grounded through the ECU.  
Text in blue is the cable markings.

### Digital input wiring

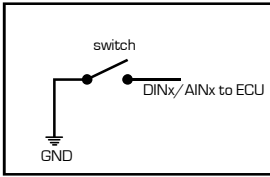

### Wiring alternative for crank / home signal

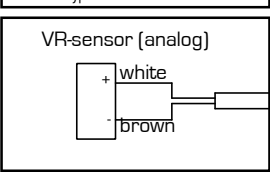
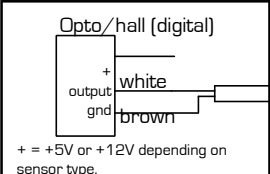

LSU connector seen from the cable side

### WB02 2

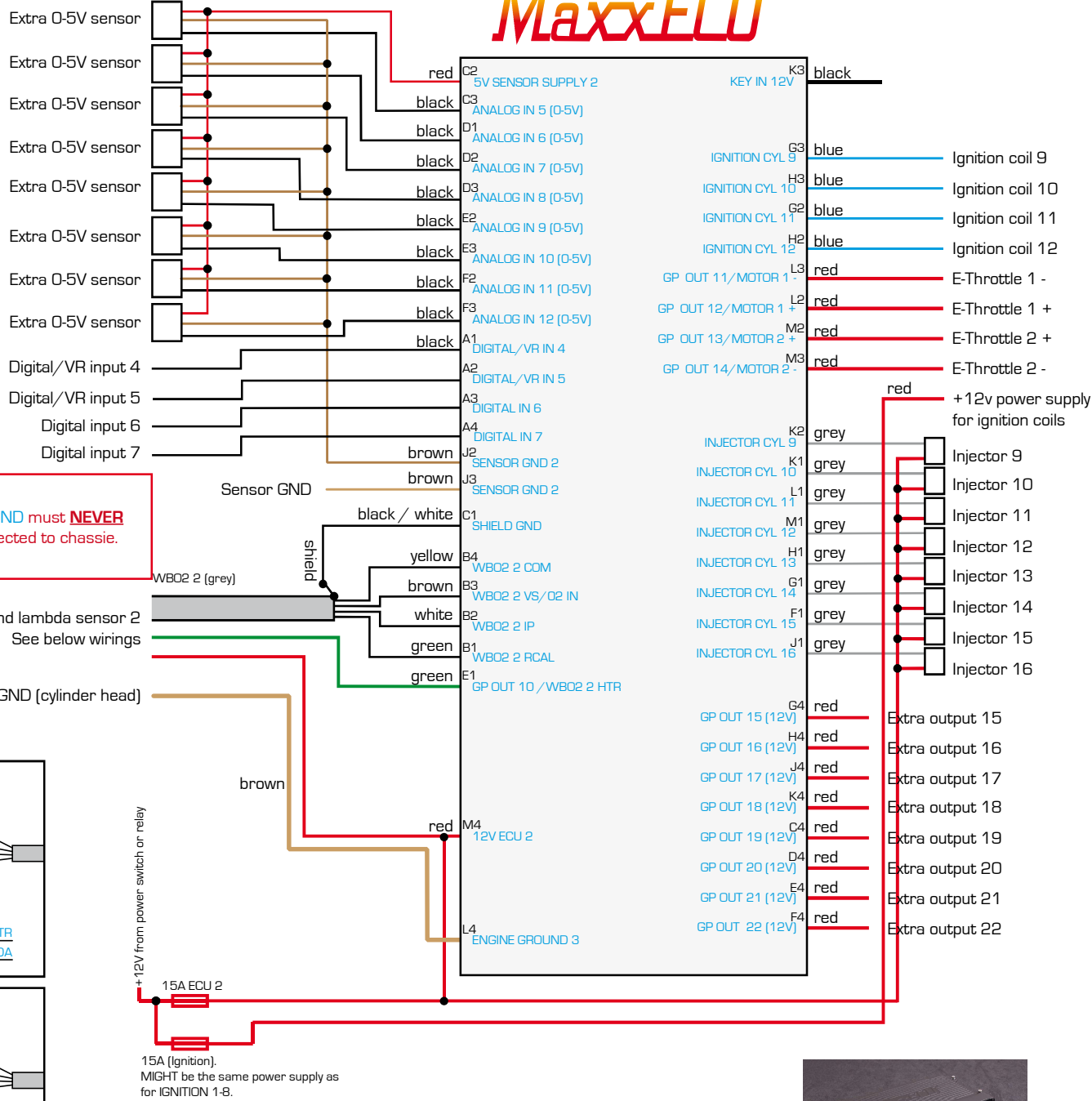
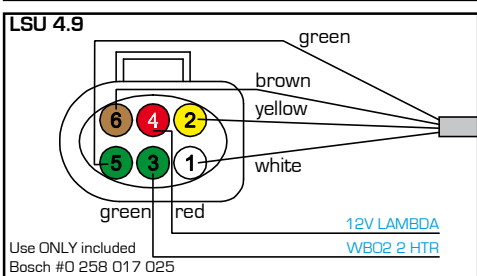
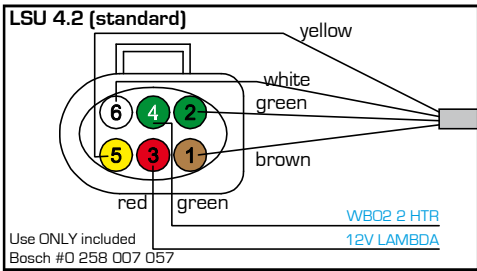

Sensor GND must **NEVER** be connected to chassie.

+12V from power switch or relay  
15A ECU 2  
15A (Ignition). MIGHT be the same power supply as for IGNITION 1-8.

## Options for connecting ignition coils

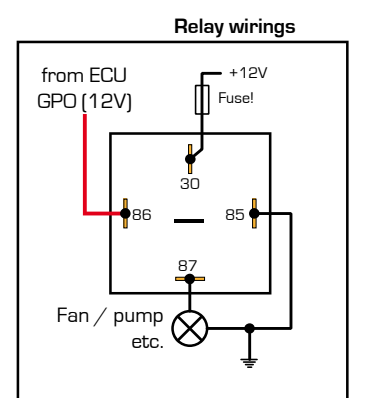
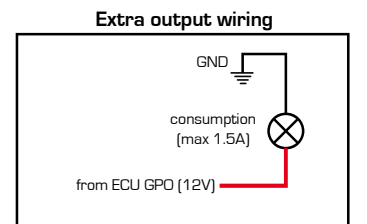
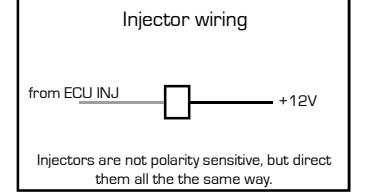
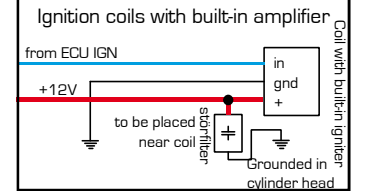
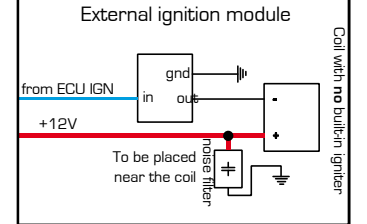

Warning: Correct sensor must be selected in MTune before usage!

**Notes:**  
 Cables shields should only be grounded through the ECU.  
 Text in blue is the cable markings.

# MaxxECU

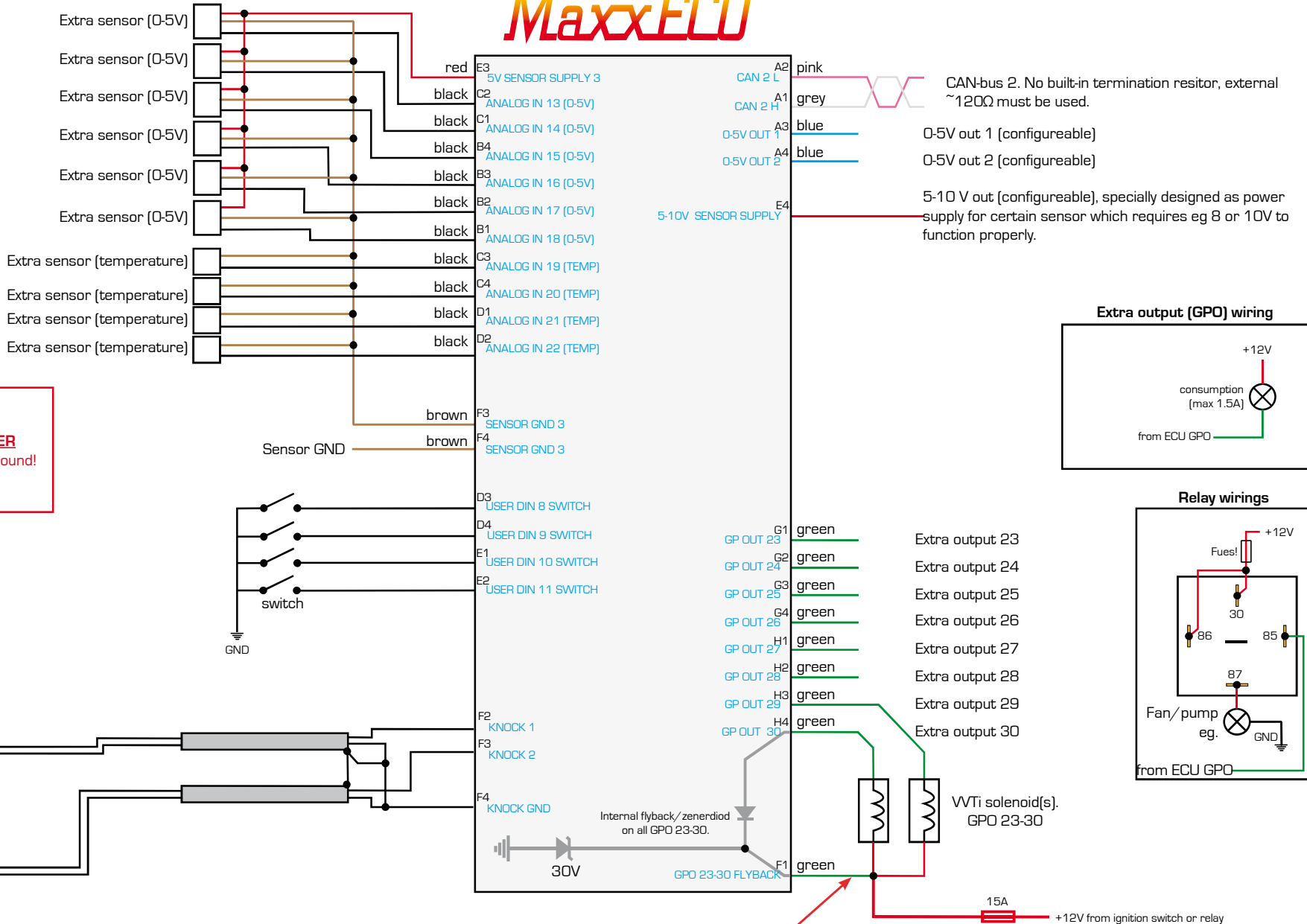

Sensor GND must **NEVER** be connected to chassis ground!

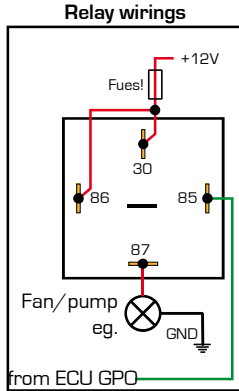
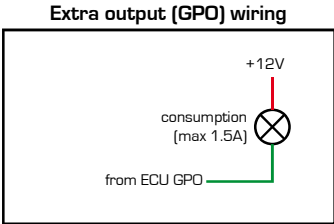

Knocksensors  
 (Bosch 0261 231 046)  
 Knock sensor(s) are not polarity sensitive

If the "GPO 23-30 FLYBACK" is NOT connected, the standard 30V internal flyback is used, which gives a faster response of the solenoids. To get 12V flyback on GPO 23-30, connect the F1 wire to the solenoid 12V power supply. This will result in slower movement of solenoids, suitable for some "floating" VVT solenoids.

