

MaxxECU

Anmärkingar:

Kabelskärmar får endast jordas via ECU.
BLÅ TEXT är kabelmärkning.

Inkoppling av digital ingång

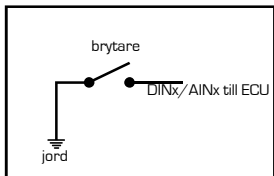

Sensor GND får **ALDRIG** kopplas mot chassie jord!

Alternativ för anslutning av vev/kamaxelgivare

Opto/hallgivare (digital)

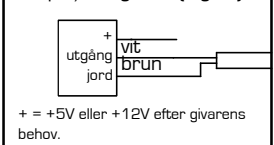

VR-givare (analog)

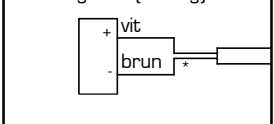

WBO2 1

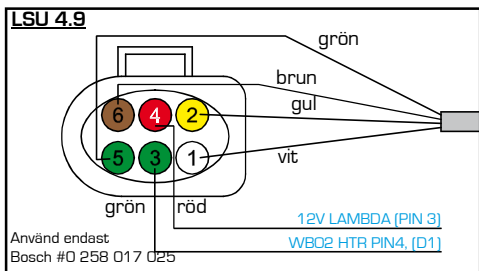
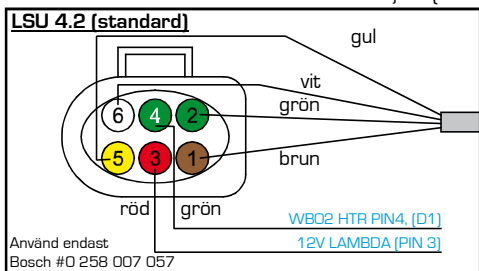

LSU kontaktdon sett från kabelsidan

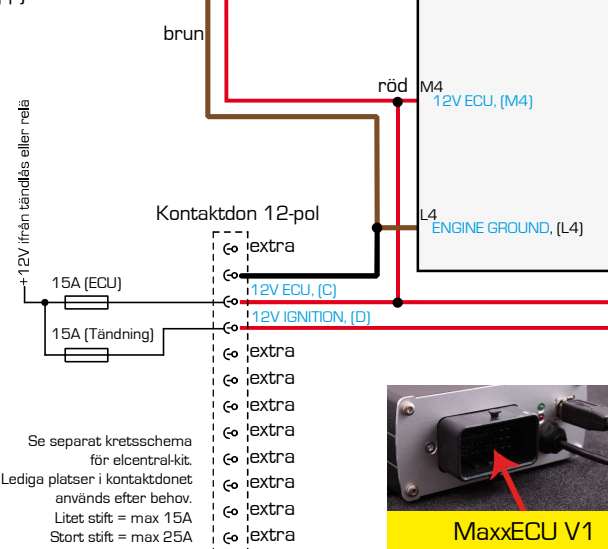
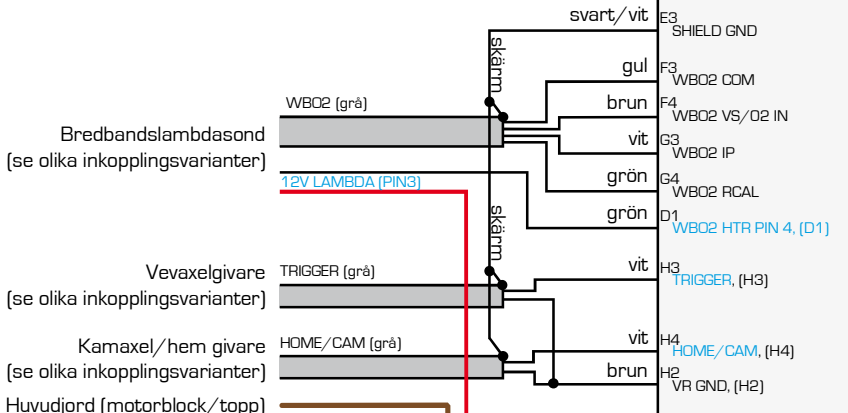
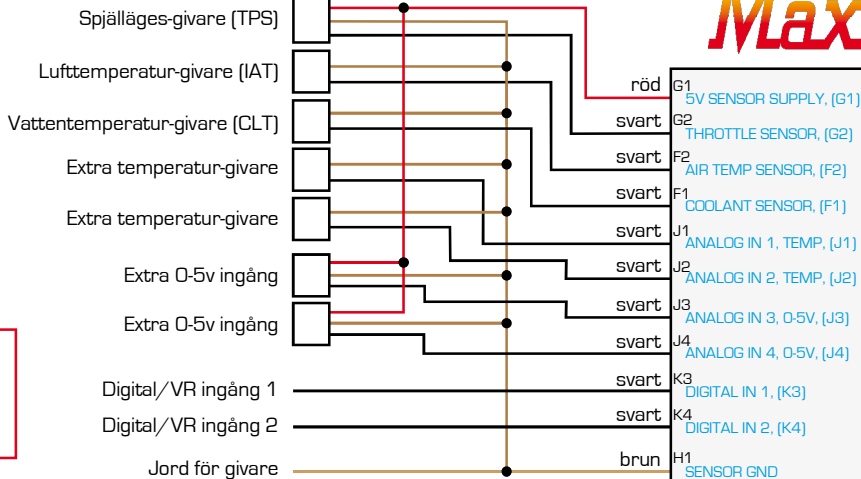

Se separat kretsschema för elcentral-kit.
Lediga platser i kontaktdonet används efter behov.
Litet stift = max 15A
Stort stift = max 25A

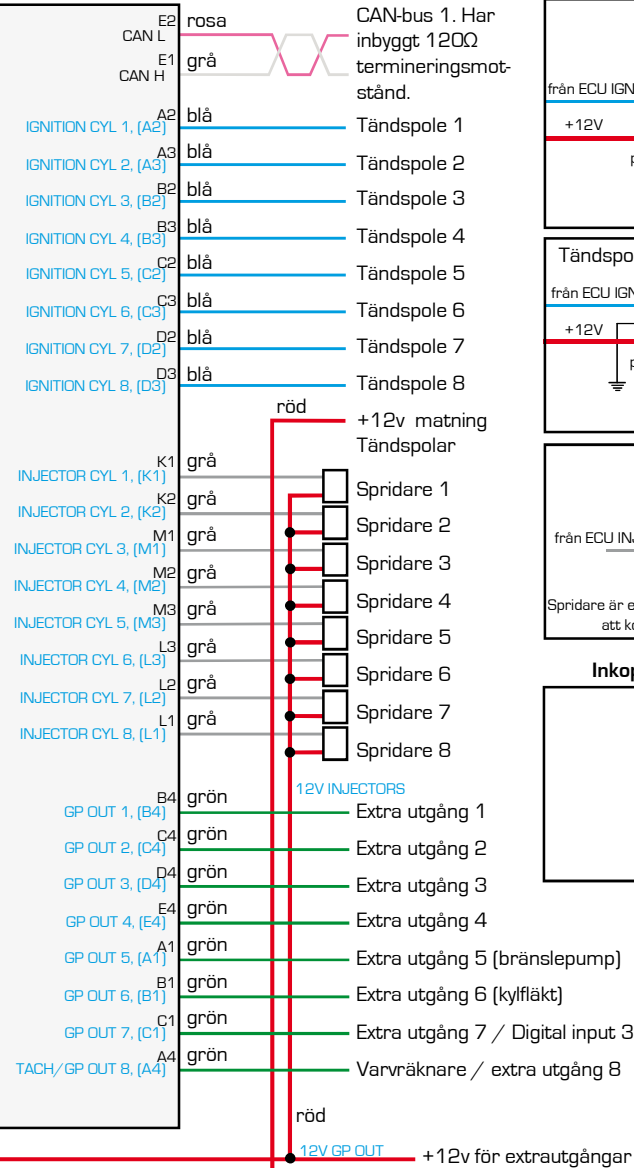

Alla GPO/INJ har 30V flyback inbyggt som standard.



MaxxECU V1
Kontaktdon 1



MaxxECU RACE
Kontaktdon 1



MaxxECU PRO
Kontaktdon 1

Alternativ för anslutning av tändspolar

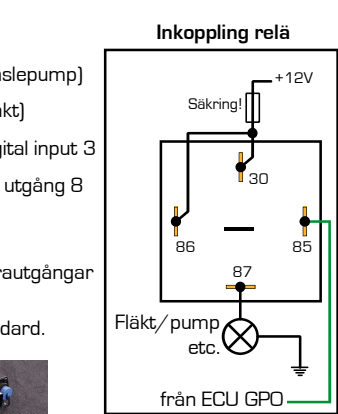
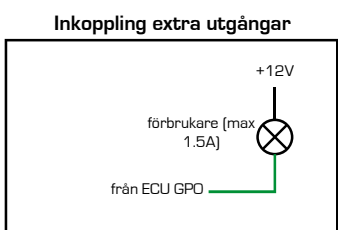
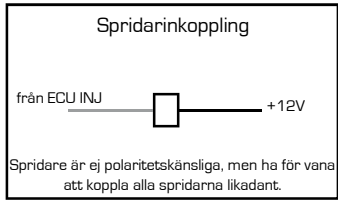
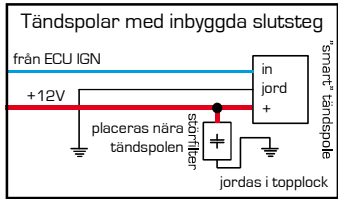
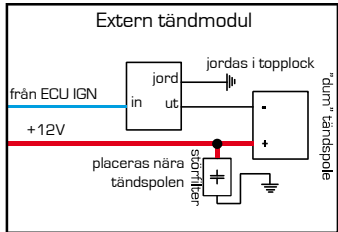

MaxxECU

Notering:
Kabelskärmmingar ska endast jordas i ECU:n (standard i kabelhärvarn)
Text i blått är kabelmärkning.

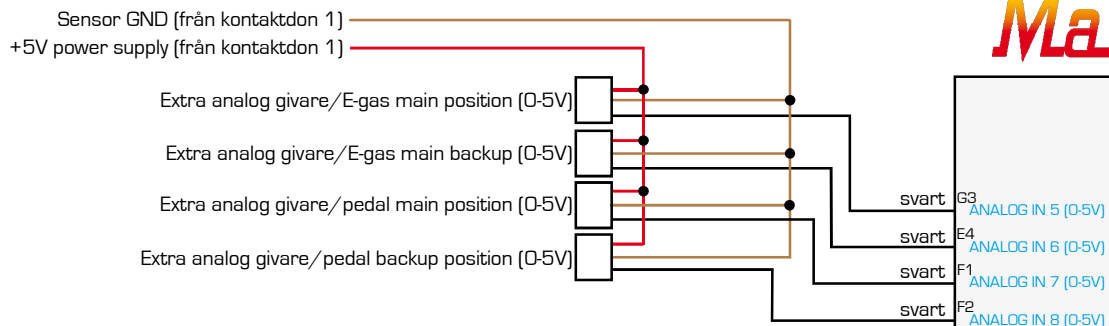

E-gas inkoppling

- De flesta e-gas spjällhus har två positionsgivare (main+backup) som kopplas till ledig analog ingång.
- De flesta pedaler har två positionerings potentiometrar (main+backup) som kopplas till lediga analoga ingångar.
- Några pedaler har en analog utgång, samt en digital PWM signal. Koppla den analoga utsignalen till en ledig analog ingång, samt den digitala PWM signalen till en ledig digital ingång (DIN/VR).

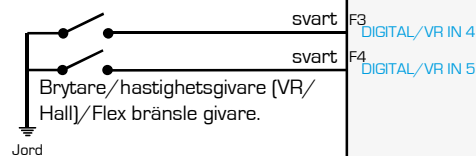

Knackgivare #1



Knackgivare #2



Knackgivare
(Bosch 0261 231 046)

Knackgivare är inte polaritetskänsliga.

Jord (motorns cylinder/topp)

Måste anslutas på samma ställe som motorjorden på kontaktdon 1.

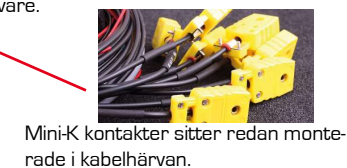
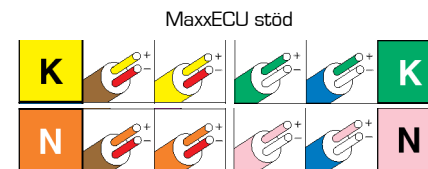
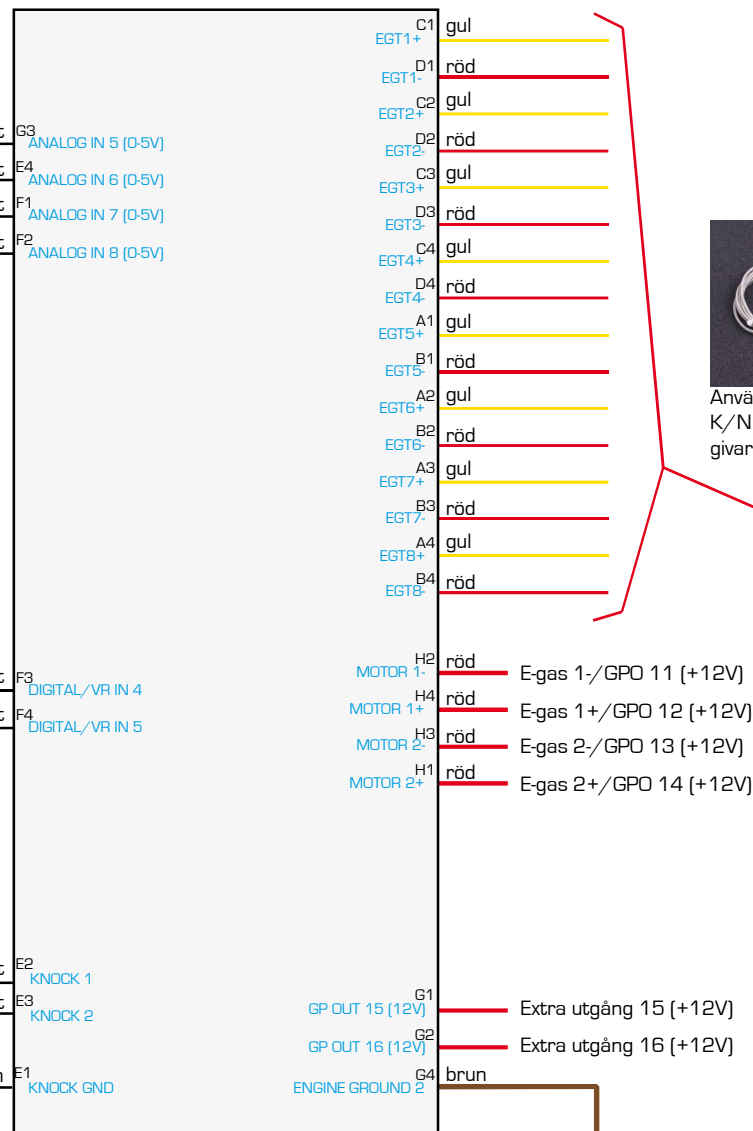

Extra utgångar (GPO +12V) inkoppling

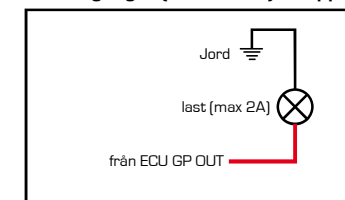

Relä inkoppling (GPO +12V)

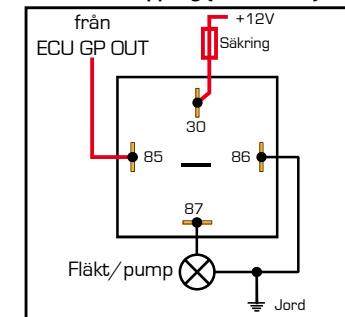

MaxxECU RACE
Kontaktdon 2